

ASSEMBLY

IMPORTANT ASSEMBLY INFORMATION

- Need phillips screw driver and 2 adjustable wrenches (putting the trampoline together). A rubber mallet may make assembly easier, however.
- Assembly requires two persons.
- Wear gloves to protect your hands from pinch points during assembly.

TRAMPOLINE PLACEMENT

1. Place the trampoline on a level surface before using it.
2. Adequate overhead clearance is essential. A minimum of 24 feet from ground level is best. Provide clearance for wires, tree limbs, and other possible hazards. Lateral (sideways) clearance is also essential. Place the trampoline away from walls, structures, fences, and other play areas. Always have a clear space on all sides of the trampoline.
3. Use the trampoline in a well-lighted area. Electric lights may be required for shady areas.
4. Secure the trampoline against unauthorized and unsupervised use.
5. Remove any objects from beneath the trampoline.
6. The owner and supervisors of the trampoline are responsible to make all users aware of practices specified in this manual.

1. Make sure that you understand the information in the box at the top of this page.

Lay two Top Tubes with attached sockets (2) (A and C in the inset drawing) and one top tube (1) without socket (B in the inset drawing) on the ground in the positions shown. Make sure the Top Tubes are turned so the small holes (spring holes) are facing the ground.

Insert one end of the Top Tube without socket (B) into the socket of Top Tube C. Insert the opposite end of the Top Tube without socket (B) in the end of Top Tube with socket (A). The Top Tubes and Sockets should now appear as shown in step 2, below.

2. Slide two Leg Extensions (3) onto a Brace (4) as shown. The peak of the Brace (4) should point toward the ground. Screw the two screws (8) into the legs (3) and Brace (4).

Insert one of the Legs (3) halfway into one of the Sockets (2) assembled in step 1. Insert the other Leg halfway into the other Socket. Press down on both Legs at the same time and fully insert them into the Sockets.

Note: You may need to pull outward on the Legs as you insert them into the Sockets.

Repeat steps 1 and 2 three additional times to assemble the remaining three leg sections.

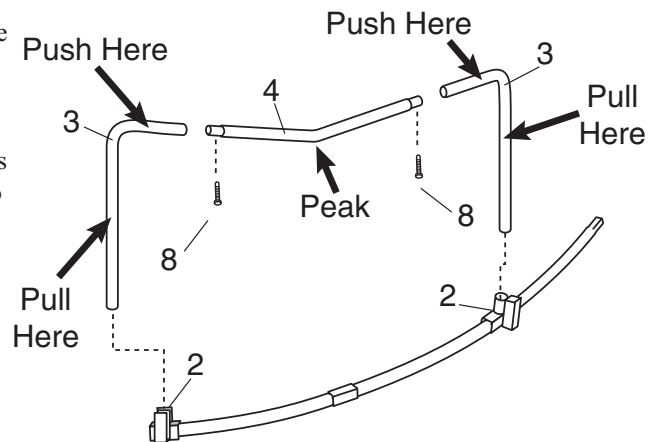
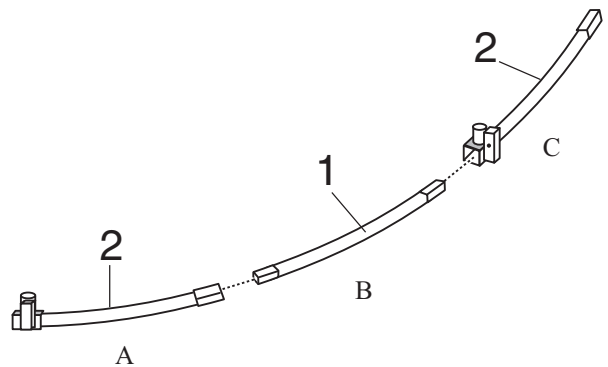

3. **Note: This step requires two persons.** During this step, you will connect the four assembled leg sections with the remaining four Top Tubes (1).

Stand two leg sections and hold them in the positions shown. Slide the large end of one of the remaining Top Tubes (1) onto the small end of the indicated Top Tube on one of the leg sections. Insert the small end of the Top Tube into the indicated Socket (2) on the other leg section. Repeat this step until all four leg sections are connected. When this step is completed, the frame will be fully assembled and freestanding.

4. Lay the Bed (Mat) (5) on the ground inside the assembled frame. Make sure that the two warning decals (not shown) are on top of the Bed (Mat).

Note: If you purchased the Skywalker Trampoline Combo, the enclosure was pre-installed on the Bed (Mat) (5) at the factory. Inspect the attachments of the enclosure Netting to the trampoline mat (bed). Make certain each of the V-rings on the trampoline mat (bed) is threaded through the corresponding "buttonhole" in the Netting. Be sure to place the opening in the Netting so it is centered under the arch where the jumpers will climb off of and onto the trampoline. If you did not purchase a Trampoline enclosure, disregard this paragraph.

Note: There are 80 V-rings around the edge of the Bed (Mat) (5) and 80 holes around the top of the frame. In Steps 4 and 5 you will attach the Bed (Mat) (5) to the frame, using 80 Springs (7).

Caution: It is wise to wear leather gloves while attaching the Springs. Be careful where you place your hands as the Springs and frame joints can pinch.

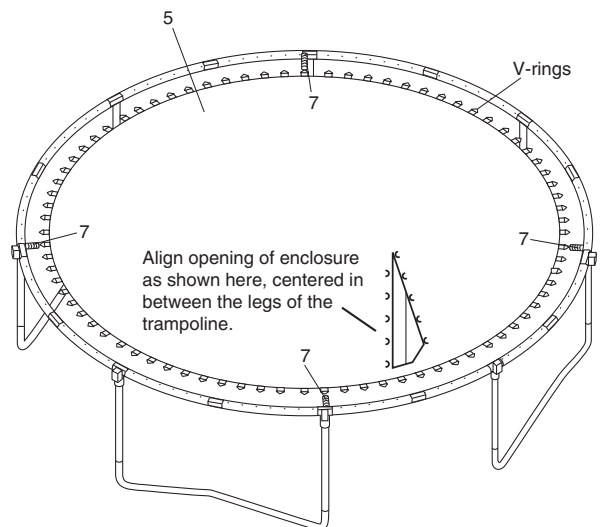
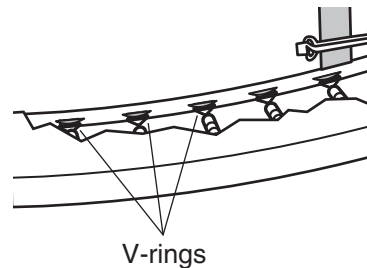
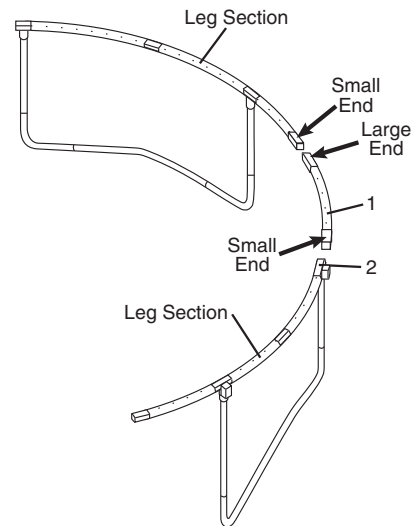

Attach the Springs (7) as follows: Hook one end of a Spring (7) into a V-ring. (See the inset drawing.) Hook a second Spring (7) (not shown) to the free end of the first Spring (7). Use the second Spring to pull the first Spring until it reaches the frame. Push the end of the first Spring into a hole in the frame. Unhook the second Spring.

After you have hooked one Spring (7) into one of the V-rings on the Bed (Mat) (5), count exactly 20 V-rings and 20 frame holes in a clockwise direction. Attach a second Spring to the V-ring and frame at this point. Count 20 V-rings and 20 frame holes in a clockwise direction and attach a third Spring. Count 20 V-rings and 20 frame holes in a clockwise direction and attach a fourth Spring.

5. After attaching the first four Springs (7), count exactly 10 V-rings and 10 frame holes in a clockwise direction. Attach another Spring to the V-ring and frame at this point. Count 20 V-rings and 20 frame holes in a clockwise direction and attach another Spring. Count 20 V-rings and 20 frame holes in a clockwise direction and attach another Spring. You will now have 8 evenly spaced Springs (7) attaching the Bed (Mat) (5) to the trampoline frame.

Attach eight Springs (not shown) evenly between the eight attached Springs in the same manner as before.

Attach sixteen Springs (not shown) evenly between the sixteen attached Springs.

Continue to attach the remaining Springs between the previously attached Springs until all Springs are attached.

Safety Note: For the Bed (Mat) (5) to have the even tension necessary for safety in jumping, the Springs (7) must be attached as described. As you attach Springs, carefully count the V-rings and frame holes. If a V-ring or hole is skipped, reattach the Springs in the proper position.

6. Lay the frame Pad (6) on the frame. Adjust the position of the Frame Pad so that the slits are directly above the Legs (3), as shown.

(If you are using the Skywalker Trampoline Enclosure, go to the Skywalker Trampoline Enclosure User's Manual, pages 8-11, for instructions in assembling the Enclosure. The Enclosure must be assembled and secured to the trampoline frame before proceeding further with trampoline assembly.)

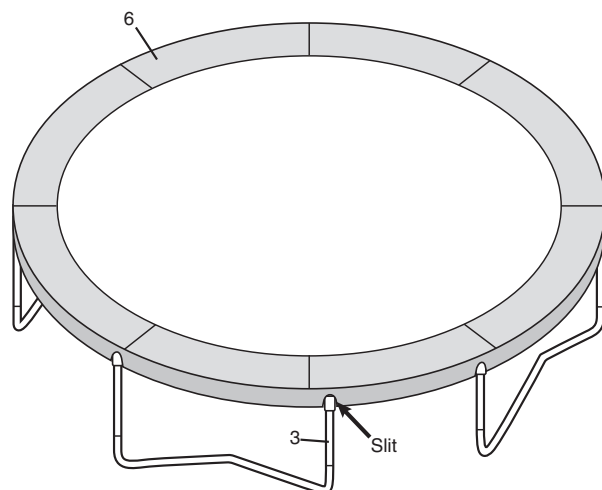
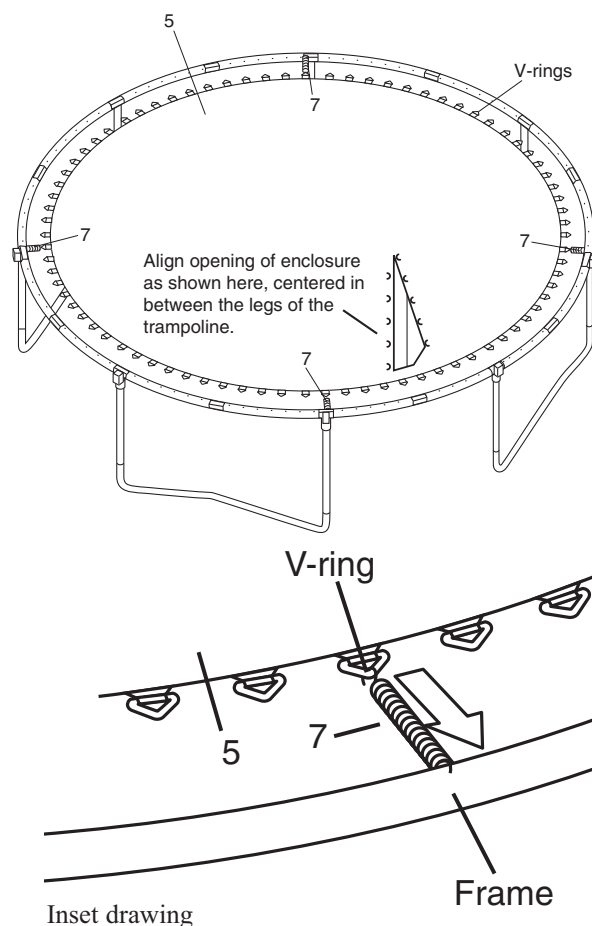

Do not use the trampoline without the Frame Pad (6). The Frame Pad is designed to reduce the possibility of injuries due to jumpers coming in contact with the trampoline frame. If you do not have a Frame Pad, contact your dealer to obtain one. Properly install the Frame Pad before using the trampoline.

7. Look under the trampoline and locate the straps and sleeves attached to the underside of the Frame Pad. Position each outer strap so that one strap is on each side of the frame as shown. Position each sleeve above a spring. Disconnect the spring and slide it through the sleeve. Then reattach the spring to the mat as shown

Repeat this with the remaining sleeves (not shown).

Refer to the inset drawing. Hold one of the straps. Wrap the longer strap under the frame and then thread the strap through the buckle on the shorter strap as shown. Pull the end of the longer strap to tighten straps. Do not overtighten the straps. Leave 1/4 inch gap.

Repeat this step with the remaining straps (not shown).

8. Using the included plastic tie, attach the Safety Placard (9) to the frame near the point where jumpers will climb onto and off the trampoline.

9. Attach the Accessories Bag (10) to the Frame in the same manner as you attached the frame pad. For increased safety, position the Accessories Bag (10) at least four feet away from the enclosure opening.

The trampoline is now fully assembled. Make sure that all parts are securely attached. Familiarize yourself and all users of the trampoline with the safety precautions, use and instructional materials, and care and maintenance instructions in this manual before using the trampoline.

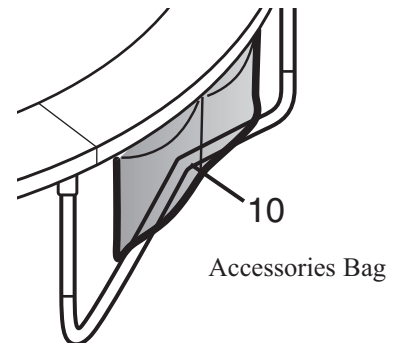
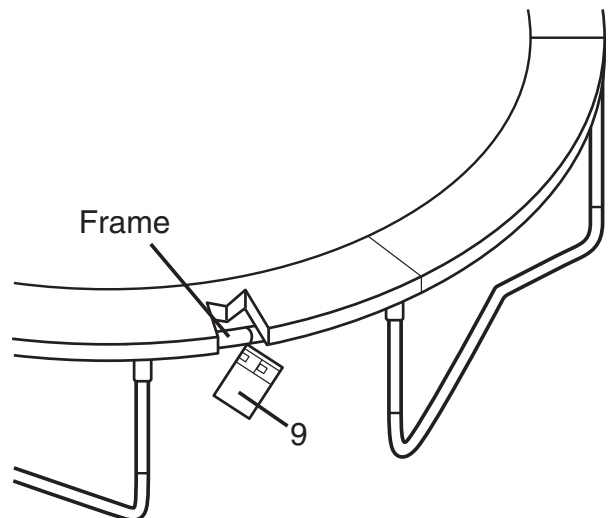
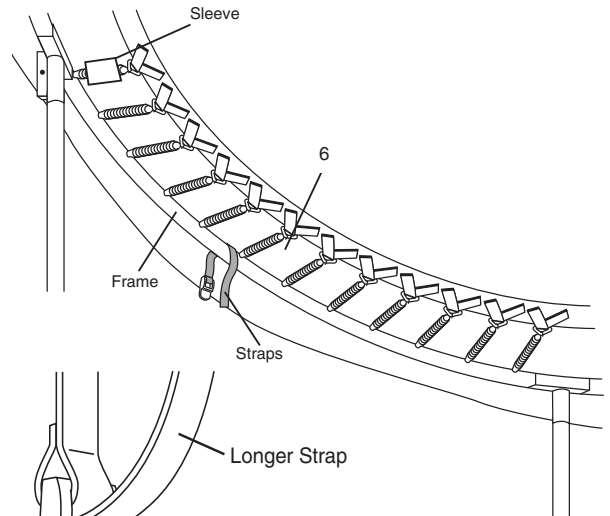

DISASSEMBLY (TAKING APART)

To disassemble (take apart) the trampoline, follow assembly steps 1 through 9 in reverse order. Do not attempt to disassemble any frame parts before the springs and the mat have been removed. Use gloves to protect your hands from pinch points while taking the trampoline apart.

EXPLODED DRAWING AND PARTS LIST

Key No.	Qty.	Description	Key No.	Qty.	Description
1	8	Top Tube	7	80	Springs
2	8	Top Tube with Socket	8	8	#8 Sheet Metal Screw 3/4"
3	8	Leg Extension	9	1	User's Manual and Safety Placard
4	4	Brace	10	1	Accessories Bag
5	1	Stitched Bed with 80 V-rings	*	1	Set of ASTM Frame Labels
6	1	Frame Pad			

* These parts are not illustrated.
Specifications are subject to change without notice.

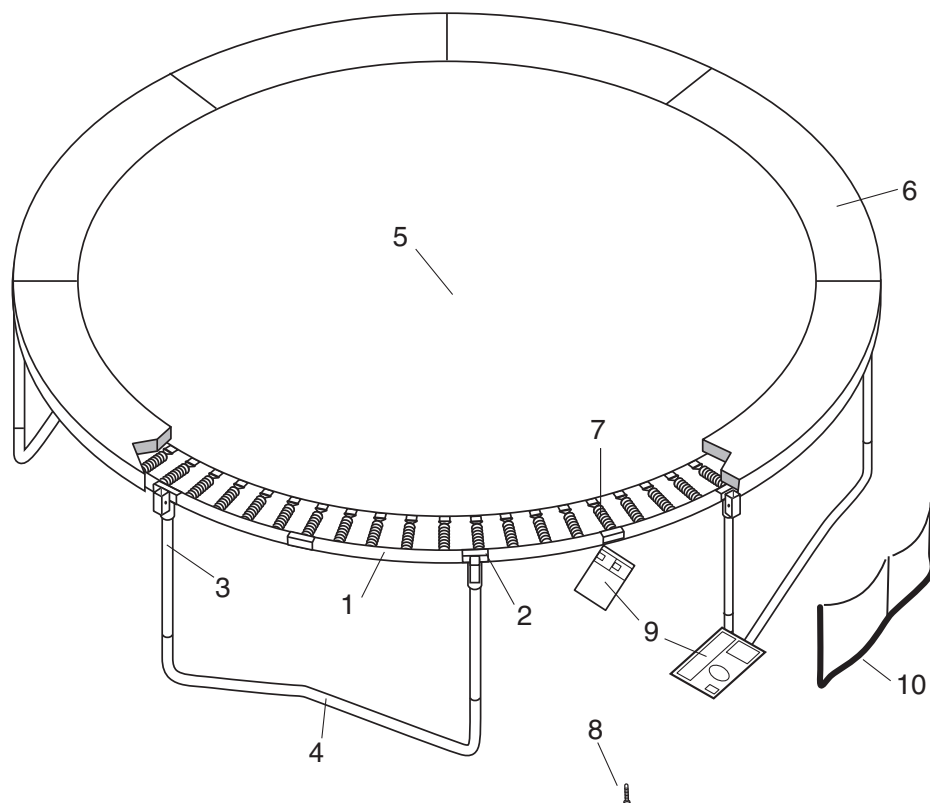

ORDERING REPLACEMENT PARTS

To order replacement parts, visit our web site at www.skywalkertrampoline.com or call our toll-free Customer Care Hot Line at 1-866-603-Jump (5867), Monday through Friday, 8 a.m. until 5 p.m. Mountain Time (excluding holidays). To help us assist you, please provide the following information when calling:

- the MODEL of the trampoline (see the front cover of this manual)
- the KEY NUMBER and DESCRIPTION of the part (see the PART LIST above)
- the quantity needed
- the desired method of shipping.

ASSEMBLY

ASSEMBLY (PUTTING THE ENCLOSURE TOGETHER)

IMPORTANT ASSEMBLY INFORMATION

- Need phillips screw driver and 2 adjustable wrenches (not included).
- Assembly requires two adults. Keep children away from the trampoline enclosure until it is completely put together.
- Use gloves to protect your hands from pinch points while putting the enclosure together.
- Make sure that the trampoline is properly put together, with the frame pad correctly laid out, before you put together the trampoline enclosure.
- The assembly steps refer to parts by their descriptions and key numbers (see the PARTS LIST on page 13 and make sure that all listed parts are included. If a part is missing, refer to ORDERING REPLACEMENT PARTS at the bottom of page 13.

TRAMPOLINE PLACEMENT

1. Place the trampoline and enclosure on a level surface before you use it.
2. Adequate overhead clearance is essential. A minimum of 24 feet (7.3 meters) from the ground is recommended. Provide clearance for wires, tree limbs, and other possible hazards. Lateral (sideways) clearance is also essential. Place the trampoline and enclosure away from walls, structures, fences, and other play areas. Maintain a clear space on all sides of the trampoline and enclosure.
3. Use the trampoline and enclosure in a well-lighted area. Artificial (electrical) lighting may be required for shady areas.
4. Secure the trampoline and enclosure against unauthorized and unsupervised use.
5. Remove any objects from under the trampoline and enclosure.
6. The trampoline enclosure is only to be used as an enclosure for a round trampoline.

1. Make sure that you understand the information in the box at the top of this page.

2. Lay two Straight Tubes (6), two L-tubes (7), and a Curved Tube (8) on the ground so they form an arch. Make sure that the Straight Tubes are oriented so the small holes are in the positions shown. The frame should be completely assembled with the screws. Then carefully slide the foam sleeves onto the frame.(9). Note: The ends of the Straight Tubes should not be covered.

Insert the two L-tubes (7) into the two Straight Tubes (6). Next, insert the two L-tubes into the Curved Tube (8).

Tighten four Self-tapping Screws (5) into the small holes in the Straight Tubes (6) and the Curved Tube (8). Note: The Small holes may be on the opposite side of the Curved Tube.

Assemble (put together) the remaining Straight Tubes, L-tubes, Curved Tubes, and Foam Sleeves in the same way.

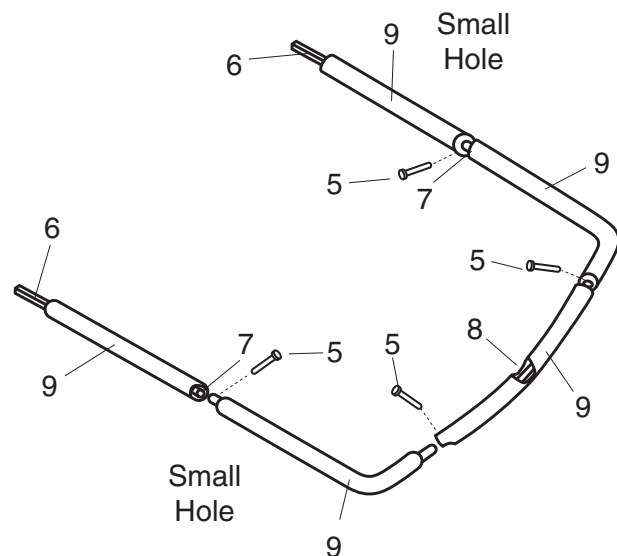

3. Note: In Step 3 you will secure the Enclosure arches to the frame of the trampoline.

Lift one of the arches assembled in Step 2 and insert the two Straight Tubes (6) into the tops of the two trampoline frame Square Sockets (4) as shown.

Insert a bolt (2) through the matching holes in the left side Straight Tube (6) and Square Socket (4).

Screw a lock nut (3) onto the bolt inserted through the Straight Tube (6) and Square Socket (4).

Firmly tighten the lock nut onto the bolt (2).

Repeat this procedure to bolt the right side of the arch to the trampoline frame.

The arch of the enclosure should now be securely bolted to the trampoline frame. If the enclosure arch does not appear to be tightly secured to the trampoline frame you will need to further tighten the lock nuts.

Attach the other three arches to the trampoline frame in the same manner (not shown).

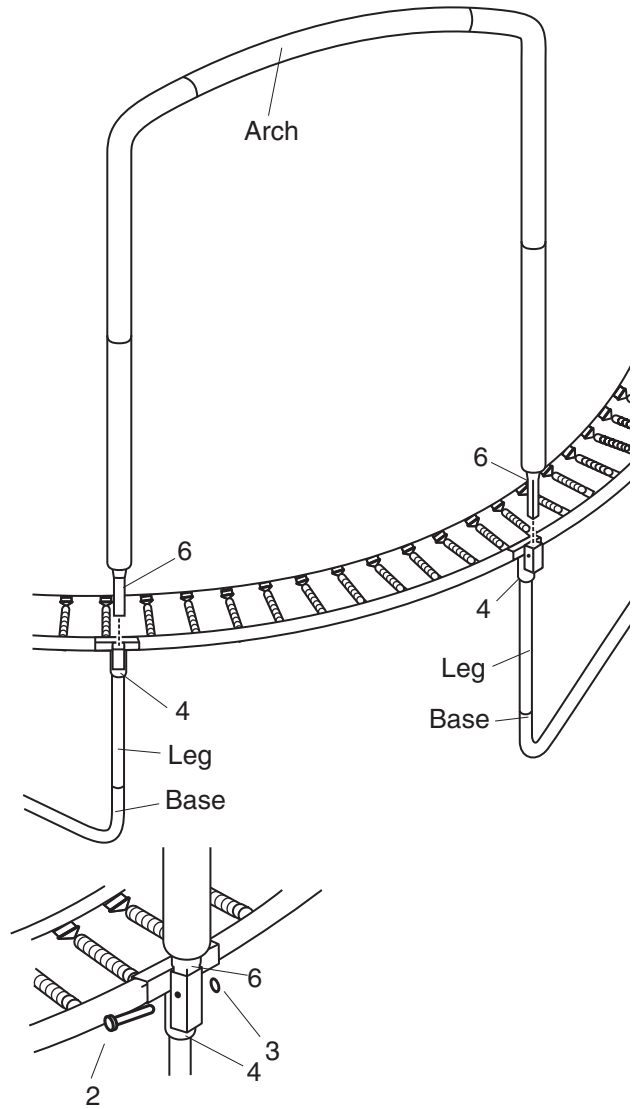

4. Locate one strap(11) with D-rings to the upper edge of the Netting. Lift the end of the strap(11) and insert it through the small belt sewn on the upper edge of the netting, see the right drawing. Then Lift D-ring and hold it close to an L-tube(7) as shown in Inset Drawing A. Next, thread the end of the Strap under the Foam Sleeve (9) on the L-tube (7) and up through the two D-rings on the opposite end of the Strap (11). (See Inset Drawing B.) Then thread the end of the Strap (11) back down through the lower D-ring on the Strap. (See Inset Drawing C.) Pull the loose end of the Strap to remove any slack but do not fully tighten the Strap (11) at this time.

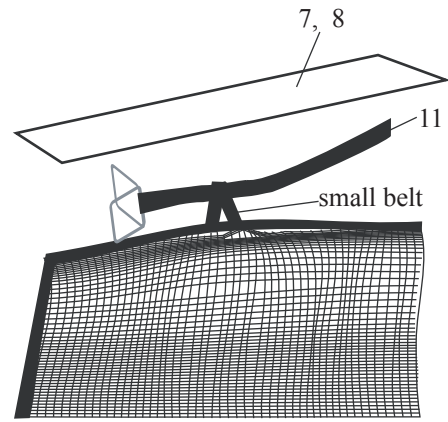

Attach the Netting (10) to the other seven L-tubes (7) with the other seven Straps (11) in the same manner.

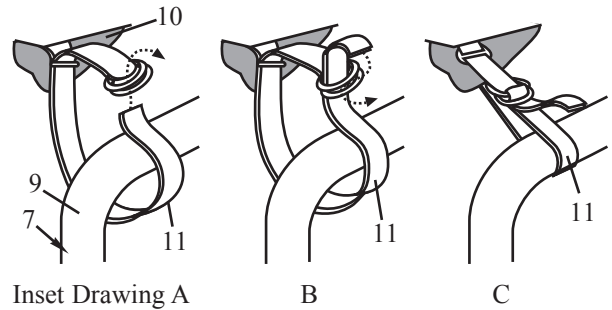

5. Tighten the eight Straps (11) attaching the Netting (10) to the L-tubes (7). (See Step 4.)

Tie the free end of each Strap (11) around the rest of the Strap (11) to prevent the Strap from becoming loose.

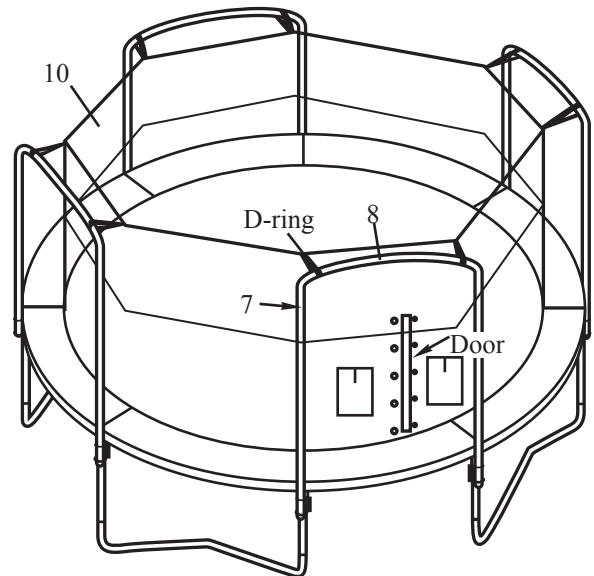

6. Tighten the Straps (not shown) on the underside of the frame pad. See Trampoline manual page 14.

7. Now insert the plastic cap into the bottom of the T-Bracket.

Your trampoline enclosure is now fully assembled (put together). Make sure that all parts are securely attached. Familiarize yourself and all users of the trampoline and enclosure with the safety precautions, use and instructional materials, and care and maintenance instructions in this manual before using the trampoline and enclosure.

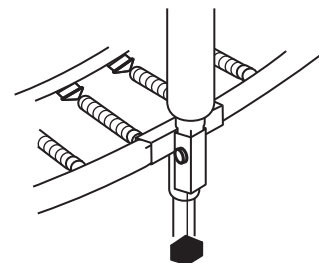

Insert plastic cap into end of T-Bracket

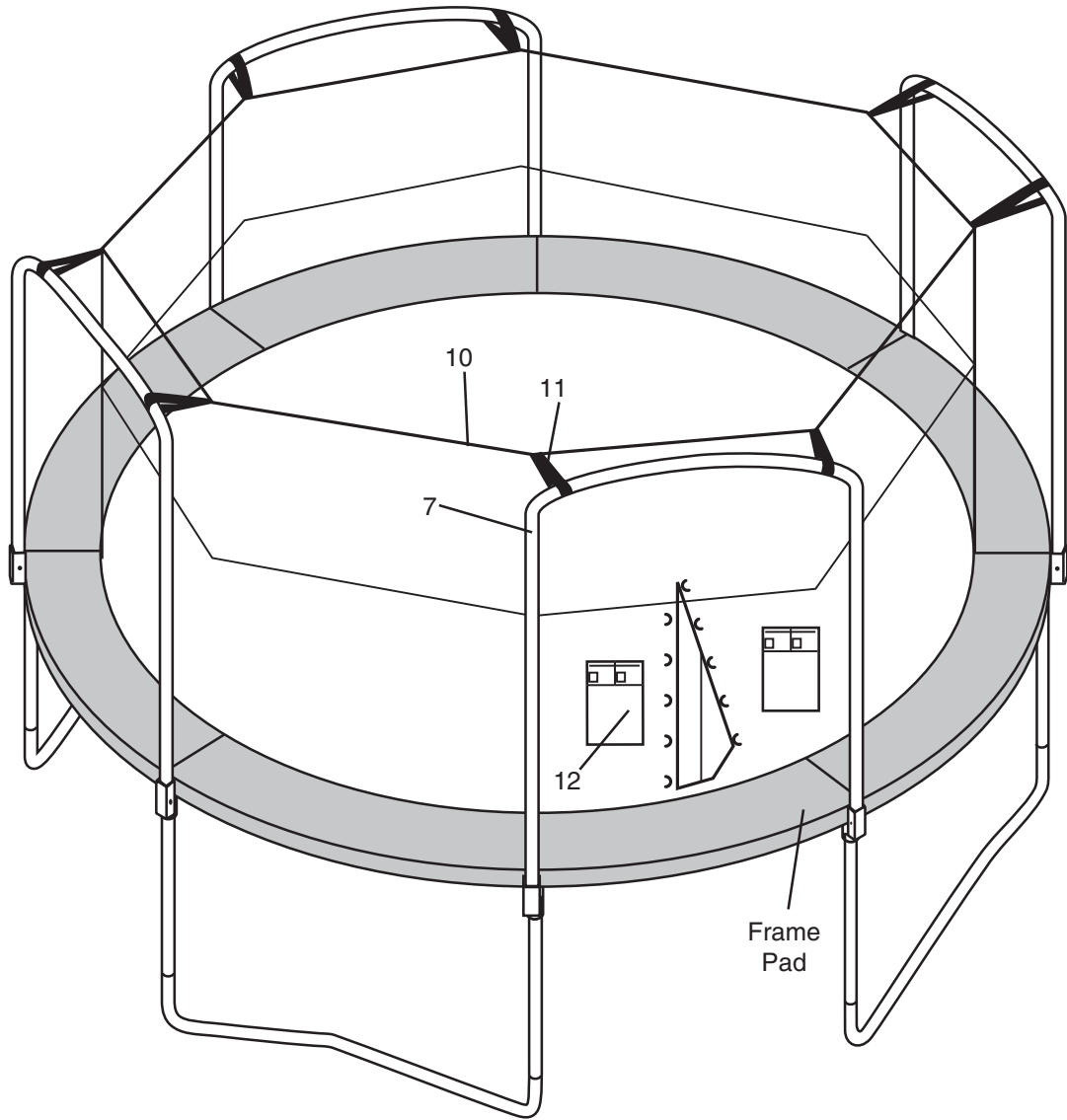

DISASSEMBLY (TAKING THE ENCLOSURE APART)

To disassemble the trampoline enclosure (take it apart), follow assembly steps 1 through 7 in reverse order.

EXPLODED DRAWING AND PARTS LIST

Key No.	Qty.	Description	Key No.	Qty.	Description
2	8	Bolt	8	4	Curved Tube
3	8	Lock nut	9	20	Foam Sleeve
5	16	Self-tapping Screw	10	1	Netting with attached Hardware
6	8	Straight Tube	11	8	Strap with D-rings
7	8	L-tube	12	1	User's Manual and Safety Placard
			13	8	End Cap

Specifications are subject to change without notice.

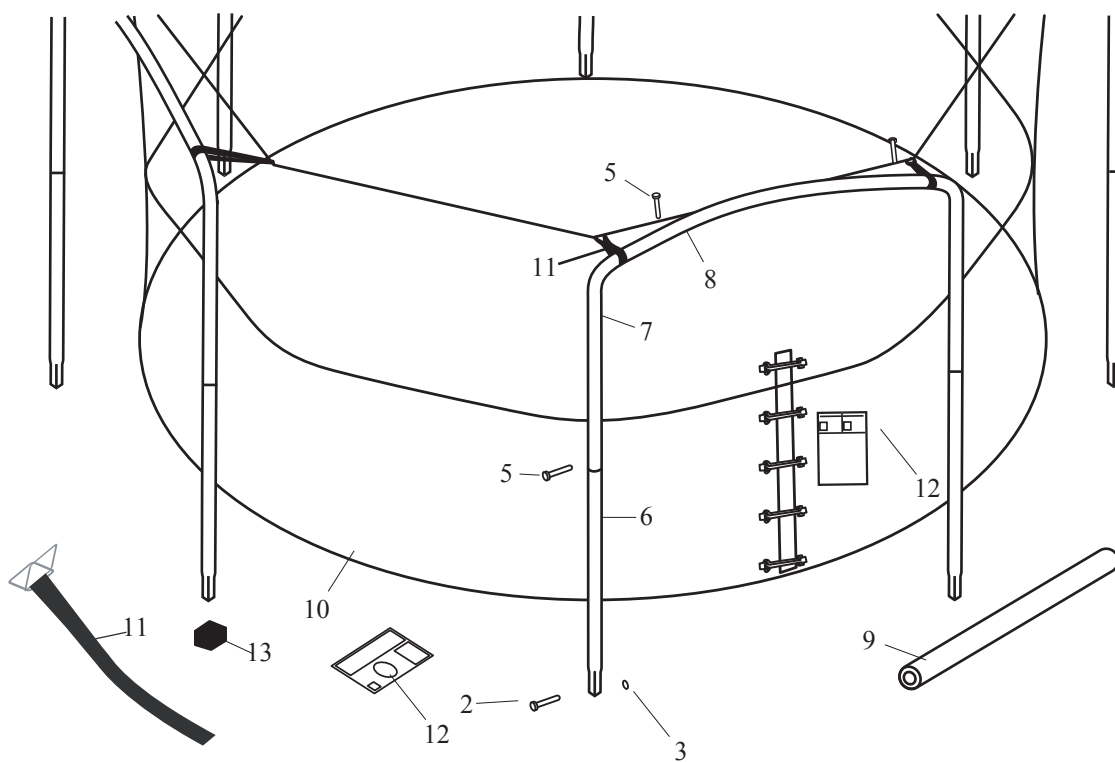

ORDERING REPLACEMENT PARTS

To order replacement parts, visit our web site at www.skywalkertrampoline.com or call our toll-free Customer Care Hot Line at 1-866-603-Jump (5867), Monday through Friday, 8 a.m. until 5 p.m. Mountain Time (excluding holidays). To help us assist you, please provide the following information when calling:

- the MODEL of the trampoline (see the front cover of this manual)
- the KEY NUMBER and DESCRIPTION of the part (see the PARTS LIST above)
- the quantity needed
- the desired method of shipping